



Austroads

SUPERSEDED PUBLICATION

This document has been superseded.
It should only be used for reference purposes.

For current guidance please visit the Austroads website:

www.austroads.gov.au

AUSTROADS TECHNICAL SPECIFICATION ATS 5630

Elastomeric Strip Seal Expansion Joints



Contents

1. Scope.....	1
2. Referenced Documents.....	1
3. Definitions.....	2
4. Quality System Requirements.....	2
5. Design.....	3
6. Materials And Manufacture.....	4
Elastomer.....	4
Anchorage.....	5
Seal Retainers.....	5
7. Certification.....	6
8. Installation.....	6
9. Warranty.....	7
Annexure A: Summary of Hold Points, Witness Points and Records.....	8
Annexure B: Typical Elastomeric Strip Seal Expansion Joint Details.....	9

1. Scope

- 1.1 Austroads Technical Specification ATS 5630 sets out the requirements for the supply and installation of elastomeric strip seal expansion joints, comprising of preformed elastomeric strip seals, metal seal retainers and anchorages. Refer to Annexure B for typical details.

2. Referenced Documents

- 2.1 The following documents are referenced in this Specification:

Australian / New Zealand Standards

AS 1214	Hot-dip galvanized coatings on threaded fasteners (ISO metric coarse thread series)
AS 1683.11	Methods of test for elastomers – Tension testing of vulcanized or thermoplastic rubber
AS 1683.13	Methods of test for elastomers - Compression set of vulcanized rubber under constant deflection
AS 1683.15.1	Methods of test for elastomers - International rubber hardness

AS 1683.23	Methods of test for elastomers - Rubber - Vulcanized - Determination of resistance to liquids
AS 1683.24	Methods of test for rubber – Determination of the resistance of vulcanized or thermoplastic rubbers to ozone cracking – Static strain test
AS/NZS 4680	Hot-dip galvanized (zinc) coatings on fabricated ferrous articles
AS 5100.4	Bridge design – Bearings and deck joints
AS/NZS ISO 9001	Quality management systems – Requirements

International Standards

ISO 188	Rubber, vulcanized or thermoplastic — Accelerated ageing and heat resistance tests
---------	------------------------------------------------------------------------------------

Waka Kotahi NZ Transport Agency

SP/M/022	Bridge Manual
----------	---------------

ASTM International

ASTM D746	Standard Test Method for Brittleness Temperature of Plastics and Elastomers by Impact
ASTM D2240	Standard Test Method for Rubber Property—Durometer Hardness

3. Definitions

- 3.1 In addition to the definitions in AS 5100.4 (in Australia) or SP/M/022 (in New Zealand), the following definition applies to this Specification.

Principal’s Registration Scheme:	Any scheme for the prequalification, registration or approval of products, manufacturers, suppliers and/or Professional Engineers in operation in the jurisdiction where the expansion joint is to be installed
-----------------------------------------	-----------------------------------------------------------------------------------------------------------------------------------------------------------------------------------------------------------------

4. Quality System Requirements

- 4.1 The Contractor must prepare and implement a Quality Plan that includes the documentation in Table 4.1.

Table 4.1 Quality Plan

Clause	Description of document
5	Description of the proposed expansion joint and general arrangement drawings showing the details of the expansion joint (including drainage requirements where appropriate)
6.3	Laboratory test certificates
7	Certification from the manufacturer of the expansion joint.
8.1	Details and / or procedures for installation
9	The wording of the proposed warranty

- 4.2 The expansion joint must be manufactured under a Quality Management System which is certified as complying with AS/NZS ISO 9001 by a JAS-ANZ accredited organisation and evidence of the certification must be submitted to the Principal.
- 4.3 Where a Principal's Registration Scheme is in place for the supply of bridge deck expansion joints, the joint must be approved under that scheme and a certificate of compliance must be submitted to the Principal. If a Principal's Registration Scheme does not apply, the Contractor must submit documentary evidence of the proven performance of the joint and compliance with this Specification with the Quality Plan.
- 4.4 For expansion joints installed in New South Wales, the joints must be an approved product. Refer to BTD 2008/11, available from: <https://roads-waterways.transport.nsw.gov.au/business-industry/partners-suppliers/disciplines/bridge.html>.
- 4.5 For expansion joints installed in Queensland, the joints must be an approved product. Refer to Product Index for Bridges and Other Structures, available from: <https://www.tmr.qld.gov.au/business-industry/Business-with-us/Approved-products-and-suppliers/Bridges-and-other-structures-approved-products-and-suppliers>

HOLD POINT 1.

Process Held	Installation of the Expansion Joint
Submission Details	The Quality Plan and the documentation required under Clause 4.2 and 4.3 must be submitted to the Principal at least 15 working days prior to the commencement of the installation of the Expansion Joint.

5. Design

- 5.1 The design of the joint must comply with AS 5100.4 (in Australia) or SP/M/022 (in New Zealand) and as amended by this Specification.
- 5.2 The elastomeric seal must accommodate the range of movement nominated on the drawings. A flush (alternatively referred to as 'cellular') neoprene strip seal must be used, unless the skew of the bridge exceeds the maximum skew recommended by the manufacturer for this type of seal. For bridges with a greater skew, a draped seal must be used, subject to the manufacturer's approval for its use in these circumstances. Refer to Annexure B Figure B3 for further details of the seal type. The design of the joint must account for skewness of bridge and racking effect when joint is installed for bridge with skew orientation.
- 5.3 The width of the seal must be sufficient to ensure that it is not damaged or pulled out of the retainer at the maximum design gap width but must not be wider than required to avoid entrapment of debris that will cause the seal to split and fail.
- 5.4 Further to any design requirements specified the Contract documents (such as in a design report):
 - a) The design forces in the anchorages must be determined on the assumption that the concrete above the point where the anchorage enters the concrete is ineffective.
 - b) Bars used as anchorages must form a loop of sufficient size to be permit anchoring into the concrete with the contribution of the transverse and other reinforcement; and
 - c) The welding of anchorage bars of the metal seal retainer must develop the full strength of the bar and accommodate an infinite number of fatigue cycles in accordance with AS 5100.4.
- 5.5 The system shown in Annexure B, Figure B2, may only be used if specified in the Contract documents and only on a bridge which has an asphalt deck wearing surface without a cast in-situ deck slab (such as transversely stressed deck unit bridges). The system comprises of a threaded stainless steel socket that is cast into the concrete. The strip seal retainers are subsequently attached and held in place by threaded studs and nuts on a bed of epoxy mortar. The dimensions of the components must not be less that that shown in Figure B2.

- 5.6 Chemical set anchorage systems or mechanical anchors are not permitted for new construction work.
- 5.7 The design, supply and installation of joint must account for assumed temperature at joint installation, proposed installation gap and gap width adjustment based on variation of temperature at the time of installation, nominated on the drawing. The joint installation and gap width must remain within allowable minimum and maximum installation gap of joint in accordance with manufacturer's specification.

6. Materials And Manufacture

Elastomer

- 6.1 The preformed elastomeric seal for the joint must be made from vulcanized compound having polymerized chloroprene as the only base polymer.
- 6.2 Unless approved otherwise by the Principal, testing must be performed by a laboratory which is accredited by a body that is a signatory to the International Laboratory Accreditation Cooperation Mutual Recognition Arrangement (ILAC MRA). The National Association of Testing Authorities (NATA) and International Accreditation New Zealand (IANZ) are signatories to ILAC MRA.
- 6.3 Documentary evidence must be provided to the Principal to verify that the elastomer used in the manufacture of the seal has been tested in a laboratory meeting the requirements of Clause 6.2 and conforms to Table 6.3.

Table 6.3 Elastomeric Seal Properties

Test reference	Requirement	Test description
Tensile Strength	13.8 MPa minimum	AS 1683.11 (Dumb-bell test pieces)
Elongation at Break	250% minimum	AS 1683.11 (Dumb-bell test pieces)
Hardness		
Joints installed in Australia	IRHD 59±5	AS 1683.15.1
Joints installed in New Zealand	IRHD 55±5	ASTM D2240
Ageing:	Report	ISO 188 (Method A for 72 hours at 100°C)
Change in Tensile Strength	-20% to 0	AS 1683.11 (Dumb-bell test pieces)
Change in Elongation at Break	-20% to 0	AS 1683.11 (Dumb-bell test pieces)
Change in Hardness	IRHD 0 to +10	AS 1683.15.1
Resistance to Ozone	No visible cracking	AS 1683.24 (Ozone concentration 100 pphm in air, 20% strain, 100 hrs at 40°C)
Low Temperature Stiffening (Change in Hardness)	IRHD 0 to +15	AS 1683.15.1 (After 7 days at -10°C)
Change in Volume in Oil	+70% maximum	AS 1683.23 (Using Oil No. 3, after 72 hours at 100°C)
Compression Set	40% maximum	AS 1683.13 (72 hours at 100°C)
Low Temperature Brittleness	Not Brittle	ASTM D 746 (B) (at -30°C)

- 6.4 The Contractor may submit a proposal to Principal to waive the requirement for testing as above. Any such proposal must be supported by evidence that:
- a) the elastomer of the seal is supplied by a company which has a third party certified quality management system to AS/NZS ISO 9001 for the manufacture and supply of elastomer.
 - b) test certificates are supplied to prove that the elastomer meets the properties specified in Table 6.2 in Type Tests which are not more than six months old.
 - c) day to day batch quality control on the manufacture of the elastomer is exercised by performing a test which accurately measures the cure characteristics of the elastomer and highlights variations resulting from incorrect ingredients or levels thereof; and
 - d) the manufacturer establishes control points and limits on batches which have been Type Tested and uses these control points and limits for subsequent quality control purposes.
- 6.5 Each seal must be completely uniform and homogeneous throughout without imperfections, surface splits, or indentations.
- 6.6 The permissible manufacturing tolerances are nil to +2 mm in relaxed width of seal.
- 6.7 The longitudinal profile of the seal must match the bridge cross section. The seal may be bent to the required angle or straight lengths of seal may be joined an adhesive recommended by the seal manufacturer. Except for sharp changes in profile, seal lengths must be joined in the manufacturing facility.

Anchorage

- 6.8 Except for the system shown in Annexure B, Figure B2 or as otherwise approved by the Principal, round bars used as anchorages must be at least 20 mm in diameter.
- 6.9 Rectangular bars used as anchorages must have a minimum thickness of 12 mm.
- 6.10 Stud welded shear connectors used as anchors must be at least 16 mm diameter and 150 mm in length and welded to the steel retainer only by resistance welding using a welding gun. Stud shear connectors must not be welded to aluminium seal retainers.
- 6.11 If the system shown in Annexure B, Figure B2 is used (where permitted):
- a) the anchorage studs must have a slot at one end for height adjustment using a screwdriver.
 - b) the sockets and studs must be fabricated from Grade 304 or 316 stainless steel: and
 - c) studs must be supplied with one Grade 316 stainless steel nut and one Grade 304 or 316 stainless steel washer of 1.5 mm minimum thickness.

Seal Retainers

- 6.12 The metal seal retainers for the joint must be manufactured from steel or aluminium.
- 6.13 Where the tops of the seal retainers are at road level, any legs must be at least 12 mm thick.
- 6.14 Where seal retainers are concreted in position, horizontal legs must have air bleed holes of at least 12 mm diameter at not more than 600 mm centres.
- 6.15 Where any leg of a steel seal retainer is upright, welded stiffeners to the leg must be provided at no more than 300 mm spacing.
- 6.16 Extruded aluminium seal retainers must have sufficient stiffness to not require stiffeners.

6.17 Unless shown otherwise on the drawings:

- a) steel seal retainers must be hot dipped galvanized in accordance with AS/NZS 4680; and
- b) any aluminium surface which will be in contact with concrete with a non-metallic epoxy coating and coat any bolts used to anchor the aluminium seal retainer with petroleum jelly before use,

6.18 The metal seal retainer must be curved or joined to match the elastomeric seal.

7. Certification

7.1 The Contractor must provide a certificate from the manufacturer of the joint verifying that all joint components comply with the Drawings and this Specification. This must include certification from a Professional Engineer eligible for Corporate Membership of Engineers Australia that the design conforms to this Specification. For expansion joints installed in New Zealand, this Clause 7.1 does not apply.

HOLD POINT 2.

Process Held	Dispatch of the expansion joint to site.
Submission Details	The certificate from the supplier of the joint verifying its conformity with the Drawings and this Specification must be provided at least 5 working days prior to the commencement of the installation of the Expansion Joint.

8. Installation

8.1 The Quality Plan must include details and / or procedures for:

- a) deck preparation, including blockout reinforcement, dimensions and tolerances required (where applicable).
- b) anchor locations and pre-setting required to suit the bridge deck temperature at the time of joint installation.
- c) preparation of the blockout base to ensure a true and even surface on which to bed the joint units (where applicable).
- d) methods of sealing joint units at kerbs, gutters and horizontal directional changes in the bridge deck profile.
- e) method of ensuring that concrete is fully compacted around the seal retainer and anchorages (where applicable).
- f) sequence of installation of the units.
- g) method of achieving a watertight seal at the interfaces between the concrete blockout and the joint units.
- h) method of joining adjacent joint units to ensure a watertight seal.
- i) torque requirements for anchors and the method of sealing bolt hole cavities.
- j) time after completion of installation when traffic is allowed on the road.
- k) method for testing of the installed seal, including field joining and testing of the installed seal for watertightness; and
- l) procedures for installation of the seal retainers including how the specified tolerances will be achieved.

8.2 Expansion joints must be handled in a manner which prevents damage to the joints and any protective coatings.

- 8.3 The actual joint gap width at the time of sealant installation must be measured and the actual joint gap width at the assumed temperature shown on the Drawings must be deduced.
- 8.4 The expansion joint and any proprietary products must be installed in accordance with the manufacturer's instructions to the specified tolerances. The seal retainer and anchorages must be securely supported on the deck formwork so that it is not displaced during placement of concrete.

WITNESS POINT 1.

Process	Installation of expansion joint and /or placement of concrete around the joint (as applicable).
Notification	Notification must be provided at least 2 working days prior to the commencement of expansion joint installation and /or placement of concrete

- 8.5 Joints in the seal retainers are only permitted in the following locations:
 - a) for a two-lane bridge, a joint may be provided at the road centre line,
 - b) for bridges with more than two lanes, joints may be provided at the lane lines and at the crown of the road. Joints are not permitted at the edge lines.
- 8.6 The seal retainers must be within +0 and -3 mm of the levels shown on the drawings and the opening of the joint must be within ±2 mm of the opening shown on the drawings.
- 8.7 Seal must not be inserted into the retainers until at least 3 days have elapsed after all the concreting in adjacent spans or abutment is finished. The finished joint must be watertight.
- 8.8 The elastomeric seal must be inserted into the retainers using a lubricant and an insertion tool recommended by the joint supplier. The lubricant must:
 - a) be the product recommended by the joint supplier.
 - b) be compatible with the seal and the retainers and be unaffected by moisture.
 - c) contain at least 60% solids and comprise a suitable polymer blended with volatile solvents: and
 - d) have the specified consistency over the temperature range specified for the insertion of the seal.
- 8.9 Expansion joints must not be subjected to construction or traffic loading until all components of the joint have achieved sufficient strength to support the loading without damage.
- 8.10 Installation of the joint must not result in a rough ride for passengers in vehicles traversing the joint. The surface of bridge joints and bridge approach joints including surface seal area must not deviate by more than 3mm when measured along a 3m straight edge.
- 8.11 If the system shown in Annexure B, Figure B2 is used (where permitted):
 - a) the retainers must be bedded on either an approved proprietary product capable of forming a dense mortar with fine aggregate and having high levels of adhesion to concrete or a sand-epoxy mix; and
 - b) a proprietary flexible polyurethane filler or continuous channel infill must be used to cover the anchor bolt recesses.

9. Warranty

- 9.1 The expansion joint must be supplied with a manufacturer's warranty in the name of the Principal. The warranty must:
 - a) cover defective workmanship, material and serviceability (which includes watertightness of the joint).
 - b) fully cover the replacement / rectification of a defective expansion joint; and
 - c) apply for a minimum period of 5 years (in Australia) or 10 years (in New Zealand) from the date of installation.

Annexure A: Summary of Hold Points, Witness Points and Records

The following is a summary of the Witness Points / Hold Points that apply to this Specification and the Records that the Contractor must submit to the Principal to demonstrate compliance with this Specification.

Clause	Hold point	Witness point	Record
9.1	Installation of the Expansion Joint.		Quality Plan, details of the expansion joint and warranty
7.1	Dispatch of the expansion joint to site		Certificate of Conformance
8.1		1. Installation of expansion joint and /or placement of concrete around the joint	
9			Warranty

Annexure B: Typical Elastomeric Strip Seal Expansion Joint Details

Figure B1: Typical Details – Seal retaining strip and anchors integrally cast in concrete

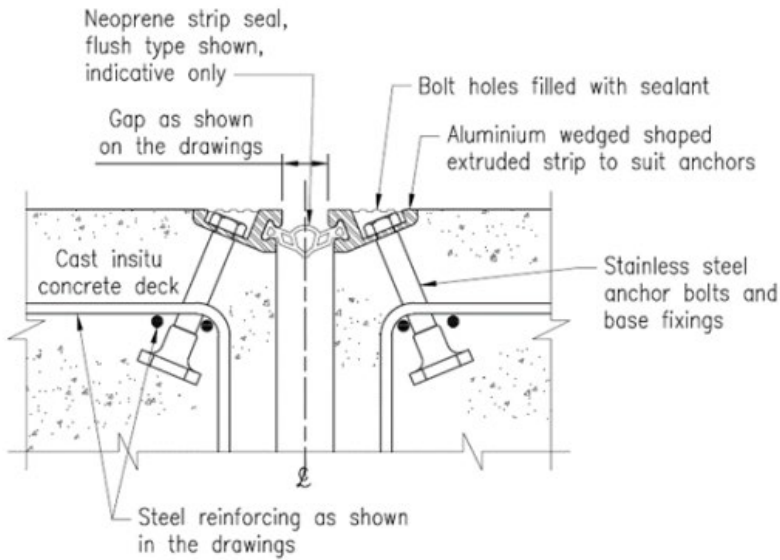

Figure B2: Typical Details – Seal retaining strip attached after the anchors have been cast in the concrete ('Bolted-In' Type – only permitted where specified in the Contract documents)

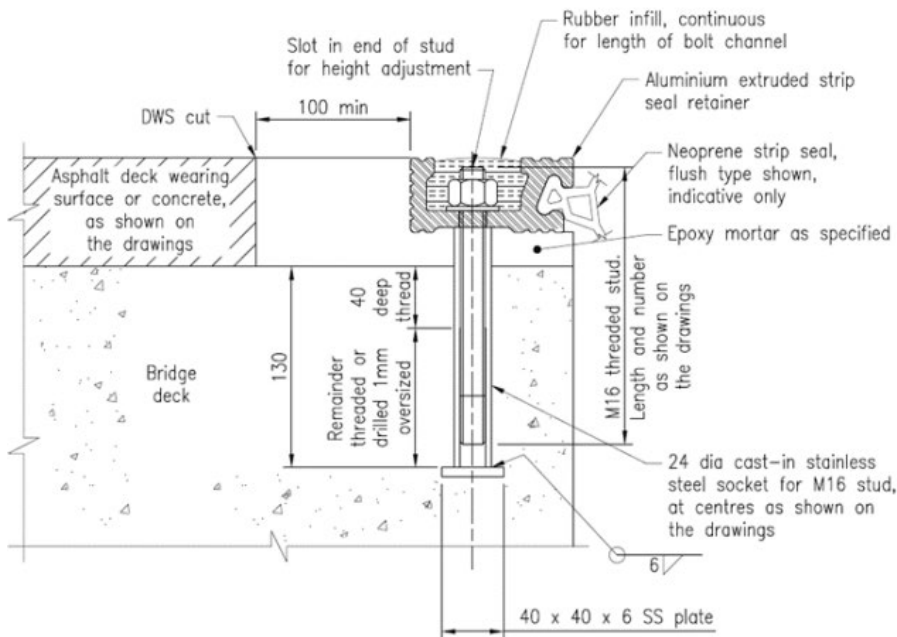
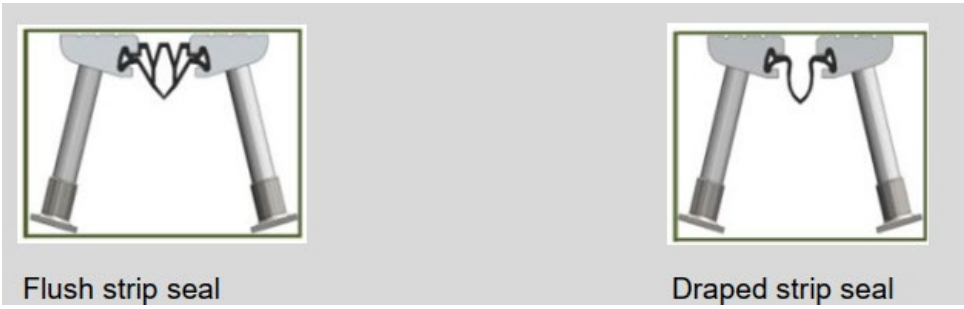

Figure B3: Typical Details – Flush and draped neoprene strip seal



Amendment Record

Amendment no.	Clauses amended	Action	Date
-	New specification	New	December 2022

Key

Format	Change in format
Substitution	Old clause removed and replaced with new clause
New	Insertion of new clause
Removed	Old clauses removed