



Austroads

SUPERSEDED PUBLICATION

This document has been superseded.
It should only be used for reference purposes.

For current guidance please visit the Austroads website:

www.austroads.gov.au

AUSTROADS TECHNICAL SPECIFICATION ATS 5610

Compression Seal Expansion Joints



Contents

1. Scope	1
2. Referenced Documents	1
3. Definitions	2
4. Quality System Requirements	2
5. Design	3
General	3
6. Materials	3
Elastomer	3
Adhesive Lubricant	5
7. Manufacture	5
8. Installation	6
9. Warranty	7
Annexure A: Summary of Hold Points, Witness Points and Records	8
Annexure B: Typical Elastomeric Compression Seal Joint Details	9

1. Scope

- 1.1 Austroads Technical Specification ATS 5610 sets out the requirements for the design, supply and installation of preformed elastomeric compression seals of the open-cell type and the adhesive lubricant used for their insertion into concrete or steel faced bridge deck joints.

2. Referenced Documents

- 2.1 The following documents are referenced in this Specification:

Australian/New Zealand Standards

AS 1683.11	Methods of test for elastomers – Tension testing of vulcanized or thermoplastic rubber
AS 1683.13	Methods of test for elastomers – Compression set of vulcanized rubber under constant deflection
AS 1683.15.1	Methods of test for elastomers – International rubber hardness
AS 1683.23	Methods of test for elastomers – Method 23: Rubber – Vulcanized – Determination of resistance to liquids
AS 1683.24	Methods of test for elastomers – Method 24: Determination of the resistance of vulcanized or thermoplastic rubbers to ozone cracking – Static strain test
AS 1683.26	Methods of test for elastomers – Method 26: Rubber, vulcanized or thermoplastic – Accelerated ageing and heat resistance tests

AS 5100.4 Bridge design – Bearings and deck joints
 AS/NZS ISO 9001 Quality management systems – Requirements

International Standards

ISO 188 Rubber, vulcanized or thermoplastic – Accelerated ageing and heat resistance tests

Waka Kotahi NZ Transport Agency

SP/M/022 Bridge Manual

ASTM International

ASTM D 2240 Standard Test Method for Rubber Property – Durometer Hardness.
 ASTM D 3542 Standard Specification for Preformed Polychloroprene Elastomeric Joint Seals for Bridges
 ASTM D 4070 Standard Specification for Adhesive Lubricant for Installation of Preformed Elastomeric Bridge Compression Seals in Concrete Structure

3. Definitions

3.1 In addition to the definitions in AS 5100.4 (in Australia) or SP/M/022 (in New Zealand), the following definition applies to this Specification.

Principal’s Registration Scheme: Any scheme for the prequalification, registration or approval of products, manufacturers, suppliers and/or Professional Engineers in operation in the jurisdiction where the expansion joint is to be installed

4. Quality System Requirements

4.1 The Contractor must prepare and implement a Quality Plan that includes the documentation in Table 4.1.

Table 4.1 Quality Plan

Clause	Description of document
5	Description of the proposed expansion joint and general arrangement drawings showing the details of the expansion joint (including drainage requirements where appropriate)
6.3	Laboratory test certificates
8.1	Details and / or procedures for installation
9.1	The wording of the proposed warranty

4.2 The expansion joint must be manufactured under a Quality Management System which is certified as complying with AS/NZS ISO 9001 by a JAS-ANZ accredited organisation and evidence of the certification must be submitted to the Principal.

4.3 Where a Principal’s Registration Scheme is in place for the supply of bridge deck expansion joints, the joint must be approved under that scheme and a certificate of compliance must be submitted to the Principal. If a Principal’s Registration Scheme does not apply, the Contractor must submit documentary evidence of the proven performance of the joint and compliance with this Specification with the Quality Plan.

- 4.4 For expansion joints installed in New South Wales, the joints must be an approved product. Refer to BTD 2008/11, available from: <https://roads-waterways.transport.nsw.gov.au/business-industry/partners-suppliers/disciplines/bridge.html>.
- 4.5 For expansion joints installed in Queensland, the joints must be an approved product. Refer to Product Index for Bridges and Other Structures, available from: <https://www.tmr.qld.gov.au/business-industry/Business-with-us/Approved-products-and-suppliers/Bridges-and-other-structures-approved-products-and-suppliers>

HOLD POINT 1.	
Process Held	Installation of the Expansion Joint
Submission Details	The Quality Plan and the documentation required under Clause 4.2 and 4.3 must be submitted to the Principal at least 15 working days prior to the commencement of the installation of the Expansion Joint.

5. Design

General

- 5.1 The design of the joint must comply with AS 5100.4 (in Australia) or SP/M/022 (in New Zealand) and as amended by this Specification. The compression seal selected must accommodate the specified range of movement on the drawings.
- 5.2 The actual joint gap, as confirmed from site measurements, and the selected size of compression seal must:
 - a) permit the compression seal to be inserted.
 - b) allow the seal to compress within the seal’s design movement range to the minimum gap width at ultimate maximum bridge temperature; and
 - c) allow the seal to expand within the seal’s design movement range to the maximum gap width at ultimate minimum bridge temperature after allowing for ultimate remaining concrete shrinkage and creep effects and live load rotations.
- 5.3 The joint gap must be configured to prevent the compression seal from being pushed down further into joint gap than the depth specified for the selected size of compression seal.
- 5.4 A galvanized armour protected joint must be cast into the deck with projecting flat steel seating strips to prevent the seal squeezing down through the joint. The flat steel seating strips or lugs must be used as shown in Annexure B over the full width.

6. Materials

Elastomer

- 6.1 The seal must have multiple webs and accommodate compression by folding inwards at the top. Refer to Annexure B (informative) for typical details.
- 6.2 The preformed elastomeric seal for the joint must be made from vulcanized compound having polymerized chloroprene as the only base polymer.
- 6.3 Unless approved otherwise by the Principal, testing must be performed by a laboratory which is accredited by a body that is a signatory to the International Laboratory Accreditation Cooperation Mutual Recognition Arrangement (ILAC MRA). The National Association of Testing Authorities (NATA) and International Accreditation New Zealand (IANZ) are signatories to ILAC MRA.

6.4 Documentary evidence must be provided to the Principal to verify that the elastomer used in the manufacture of the seal has been tested in a laboratory meeting the requirements of Clause 6.2 and conforms to Table 6.3.

Table 6.3 Elastomeric Seal Properties

Test reference	Requirement	Test description
Tensile Strength	13.8 MPa minimum	AS 1683.11 (Dumb-bell test pieces)
Elongation at Break	250% minimum	AS 1683.11 (Dumb-bell test pieces)
Hardness		
Joints installed in Australia	IRHD 59±5	AS 1683.15.1
Joints installed in New Zealand	IRHD 55±5	ASTM D2240
Compression Set	40% maximum	AS1683.13 (72 hrs at 100°C)
Ageing:	None specified. Report only ⁽¹⁾	ISO 188 (Method A for 72 hours at 100°C)
Change in Tensile Strength	- 20% to 0	AS 1683.11 (Dumb-bell test pieces)
Change in Elongation at Break	- 20% to 0	AS 1683.11 (Dumb-bell test pieces)
Change in Hardness	IRHD 0 to +10	AS 1683.15.1
Resistance to Ozone	No visible cracking	AS 1683.24 (Ozone concentration 100 pphm in air, 20% strain, 100 hours at 40°C)
Low Temperature Stiffening (Change in Hardness)	IRHD 0 to +15	AS 1683.15.1 (After 7 days at -10°C)
Change in Volume in Oil	+70% maximum	AS 1683.23 (Using Oil No. 3, after 72 hours at 100°C)

Note:

1. The results must be included in the report submitted to the Principal.

6.5 The Contractor may submit a proposal to Principal to waive the requirement for testing as above. Any such proposal must be supported by evidence that:

- a) the elastomer of the seal is supplied by a company which has a third party certified quality management system to AS/NZS ISO 9001 for the manufacture and supply of elastomer.
- b) test certificates are supplied to prove that the elastomer meets the properties specified in Table 6.3 in Type Tests which are not more than six months old.
- c) day to day batch quality control on the manufacture of the elastomer is exercised by performing a test which accurately measures the cure characteristics of the elastomer and highlights variations resulting from incorrect ingredients or levels thereof; and
- d) the manufacturer establishes control points and limits on batches which have been Type Tested and uses these control points and limits for subsequent quality control purposes.

6.6 For each size of each seal type/configuration delivered, a certificate verifying compliance with this Specification must be submitted to the Principal. The certificate must not be more than one year old and identify the specific batch number. It must be issued by a laboratory complying with Clause 6.2. If the supply of raw material or the manufacturing process changes, a new Certificate must be provided. This Clause 6.5 does not apply to expansion joints installed in New Zealand

Adhesive Lubricant

- 6.7 The adhesive lubricant must provide sufficient lubrication for insertion of the seal into the joint gap at ambient temperatures. It must be a moisture cured or chemically cured single or multi component compound compatible with the seal and substrate and not be affected by moisture. It must bond the seal to the face of the joint gap and seal the joint against infiltration of moisture.
- 6.8 A lubricant that conforms to Table 6.7 and is recommended by the seal manufacturer must be used. A test report issued by the manufacturer or, if required by the Principal, by a laboratory complying with Clause 6.2, must be submitted to the Principal to verify that the lubricant complies with Table 6.7.

Table 6.7 Adhesive Lubricant Properties

Test reference	Requirement	Test description
Solids content	60% minimum	ASTM D 4070, Clause 9.1
Viscosity	20,000 to 300,000 cP	ASTM D 4070, Clause 9.2
Lubricating life	2 hours minimum	ASTM D 4070, Clause 9.3
Sag	No sagging	ASTM D 4070, Clause 9.4
Peeling strength test:		ASTM D 4070, Clause 9.5
500 g load	Zero	
1000 g load	12 mm	

7. Manufacture

- 7.1 The seal must conform to Table 7.4.
- 7.2 Following manufacture, each seal must be completely uniform and homogeneous throughout, without imperfections, surface splits or indentations.
- 7.3 The permissible tolerances for the seal cross-section are:

$$\text{Tolerance (mm)} = \sqrt{\pm 0.05 \times \text{dimension}}$$

where “dimension” is the relaxed width or overall depth of the seal in millimetres.

- 7.4 The longitudinal profile of the seal must match the bridge cross section and be obtained either by removing a portion of the seal to bend it to the required angle or by joining straight lengths using an adhesive recommended by the seal manufacturer. The seal must not be field spliced.

Table 7.4 Elastomeric Seal Properties

Test reference	Requirement	Test description
Recovery of compression seal:		ASTM D 3542, Clause 8.2
High temperature recovery after 72 hours at 100°C	80% minimum	
Low temperature recovery after 72 hours at -10 °C	88% minimum	

Notes:

Two test samples must be tested simultaneously for each recovery test. The recovery value must be the average result of the pair of samples, provided that the lowest result does not exceed a tolerance of 0 to -3% of the minimum specified recovery.

If, after a recovery test, any test sample exhibits adhesion between any internal faces, cracking in any walls or splitting, reject the batch of seal represented by the sample.

8. Installation

- 8.1 Where appropriate to the expansion joint, the Quality Plan must include details and / or procedures for:
- a) deck preparation, dimensions and tolerances required.
 - b) anchor locations and pre-setting required to suit the bridge deck temperature at the time of joint installation.
 - c) methods of sealing joint units at kerbs, gutters and horizontal directional changes in the bridge deck profile.
 - d) method of managing any conflict between joint anchors and reinforcing and ensuring that concrete is fully compacted around the armour protection joint and anchorages.
 - e) method of achieving a watertight seal.
 - f) method of protecting the expansion joint from damage due to construction activities and the passage of site vehicles.
 - g) time after completion of installation when traffic is allowed on the road; and
 - h) method for testing of the installed joint for watertightness.
- 8.2 Expansion joints must be handled and installed in a manner which prevents damage to the joints and any protective coatings and in New Zealand, in accordance with SP/M/022.
- 8.3 The seal must be installed in accordance with the manufacturer’s instructions.

WITNESS POINT 1.

Process	Installation of expansion joint.
Notification	Notification must be provided at least 2 working days prior to the commencement of expansion joint installation

- 8.4 The compression seal must not be inserted into the joint gap until all deck concrete work in adjacent spans or abutments is complete, except in the case of seals which are pre-compressed between permanent steel sections with the assembly fixed in position prior to placing the concrete.
- 8.5 The sides of the joint gap must be sound, dry and blast cleaned of all grit and loose particles before installation of the seal.
- 8.6 The joint gap and selected size of compression seal must be checked for compliance with the design requirements prior to installation. Unless specified otherwise, the following tolerances apply to the joint installation:
- a) joint gap ± 3 mm.
 - b) deviation from plan alignment 5 mm maximum over the total length of the joint; and
 - c) the top surface of the joint shall be level with the adjacent road surface with a tolerance of 0 to 2 mm when measured with a 2.5 m straight edge at 90° to the joint.
- 8.7 The upper surfaces of the joint must be parallel with the longitudinal grade and cross-fall of the completed road or footpath surface.
- 8.8 The seal must be inserted into the joint gap using the adhesive lubricant and an insertion tool recommended by the seal manufacturer.

9. Warranty

- 9.1 The expansion joint must be supplied with a manufacturer's warranty in the name of the Principal. The warranty must:
- a) cover defective workmanship, material and serviceability (which includes watertightness of the joint).
 - b) fully cover the replacement / rectification of a defective expansion joint; and
 - c) apply for a minimum period of 5 years (in Australia) or 10 years (in New Zealand) from the date of installation.

Annexure A: Summary of Hold Points, Witness Points and Records

The following is a summary of the Witness Points / Hold Points that apply to this Specification and the Records that the Contractor must submit to the Principal to demonstrate compliance with this Specification.

Clause	Hold point	Witness point	Record
5.3	Installation of the Expansion Joint.		Quality Plan, details of the expansion joint and proposed warranty
6.5			Certificate of Compliance
8.1		1. Installation of expansion joint and /or placement of concrete around the joint	
9			Warranty

Annexure B: Typical Elastomeric Compression Seal Joint Details

Figure B 1

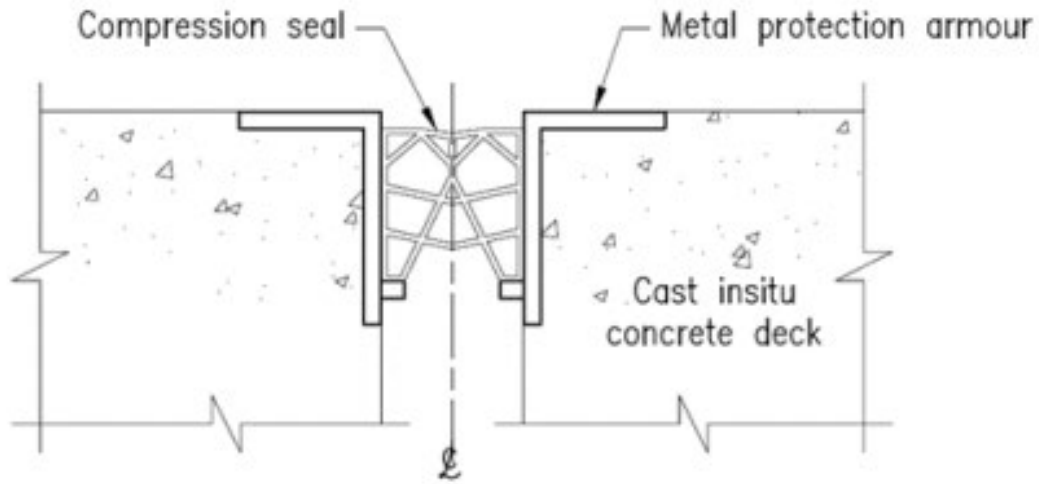

Amendment Record

Amendment no.	Clauses amended	Action	Date
-	New specification	New	December 2022

Key

Format	Change in format
Substitution	Old clause removed and replaced with new clause
New	Insertion of new clause
Removed	Old clauses removed